



A Chase Corporation Company  
23 Elm St., Peterborough, NH 03458  
Tel: (800) 543-3458 (603) 924-9481  
Fax: (603) 924-9482  
Web site: www.cimindustries.com

CIM IG-4  
07/10

## Instruction Guide APPLICATION OF CIM TO WOOD

### 1.0 DESCRIPTION

This guide covers the installation of a CIM coatings and linings (CIM) over a sound, properly prepared wood base. The CIM shall consist of a minimum of 55 dry mils (see CIM Technical Data Sheet and appropriate coverage chart) applied by spray, squeegee, roller, or trowel. Actual coverage rates may differ from theoretical rates depending on surface profile and application method.

### 2.0 MATERIALS

#### 2.1 CIM Premix and Activator

#### 2.2 Optional Materials

##### 2.2a. CIM 61BG Epoxy Primer

##### 2.2b. CIM Bonding Agent

##### 2.2c. CIM Scrim

##### 2.2d. CIM 1000 Trowel Grade Premix & Activator

### 3.0 SAFE PRACTICES

Use equipment and procedures designed to minimize danger to personnel and materials. Special attention should be made to provide adequate ventilation and respirators for personnel applying CIM in confined spaces or when operating spray equipment. See C.I.M. Industries' Instruction Guide, "Applying CIM Within Confined Spaces" (IG-9) for more detailed information.

### 4.0 SURFACE PREPARATION

All areas adjacent to those being coated with CIM which are not intended to be coated should be protected with suitable temporary splash covers such as polyethylene, carpenters paper, or masking tape. CIM shall be applied on a clean, dry, structurally sound base.<sup>1</sup> For best results, apply CIM 61BG Epoxy Primer and CIM when wood is declining in temperature (usually late afternoon). CIM 61BG Epoxy Primer may be used to minimize outgassing.<sup>2</sup>

**WOOD SHOULD NOT BE COATED WHILE IN DIRECT SUNLIGHT!** Wood should be coated only while in a temperature declining mode. CIM, because it is black, is a solar absorber and can increase the surface temperature. This, in turn, heats up the air trapped within the wood's pores. The air expands and tries to push its way out of the wood, creating hundreds of bubbles, otherwise known as outgassing. Therefore, if wood is coated in direct sunlight (e.g. a temperature rising mode), outgassing may occur.

---

#### Notes:

<sup>1</sup>If surfaces are not completely clean, CIM will achieve poor adhesion to the wood base and may experience blistering and possible failure.

<sup>2</sup>CIM 61BG Epoxy Primer shall be applied at a minimum rate of 5 wet mils. The CIM 61BG Epoxy Primer maximum recoat window is 48 hours. Please see CIM 61BG Epoxy Primer Technical Data Sheet for additional information.

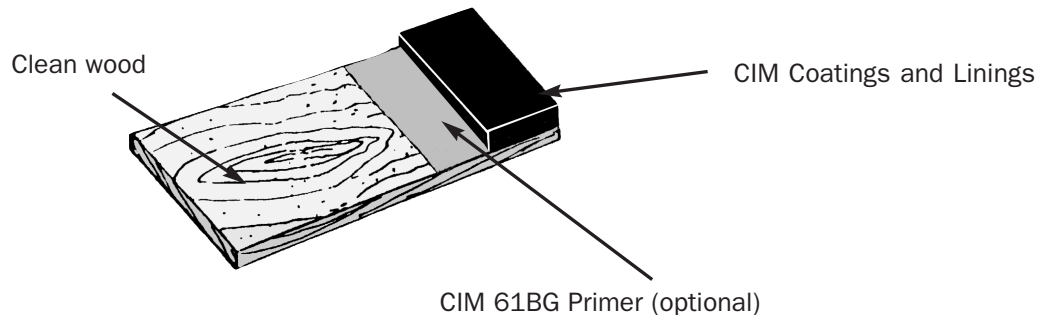

---

**NOTES:**

#### **4.1 Wood**

Wood surfaces shall be clean and must have a moisture content below 20% based on oven dry weight. Oil or grease spots shall be thoroughly cleaned. If paint or previous coatings have been applied, the surface shall be lightly sanded. All paint or previous coatings that are loose or flaking shall be removed and weathered surfaces sanded down to sound wood. Adhesion tests should be performed on any existing coatings to insure that the CIM system can achieve acceptable bond to the substrate.

CIM shall not be applied over preservative-treated wood unless specific tests for adhesion have been carried out by the owner and the results have been satisfactory. Consult with C.I.M. Industries Technical Personnel for special preparation of certain tropical woods.

#### **4.2 Joints in the Substrate**

On large plywood surfaces, the spaces between plywood sheets should utilize CIM Scrim. Apply a 10–20 mil tack coat 3” on each side of the joint. Place CIM Scrim into the tack coat, and then coat scrim with 60 mils of CIM using a roller. Allow scrim to dry for 1–2 hours before coating the entire system. Using CIM Scrim minimizes the amount of CIM that drips between the plywood sheets and helps insure proper coverage.

### **5.0 APPLICATION**

#### **5.1 Penetrations**

Penetrations must be coated with CIM 1000 Trowel Grade at all horizontal to vertical transitions. CIM 1000 Trowel Grade should be applied at least 60 wet mils thick, 2” onto and 2” beyond the penetration. Please see section 5.7 for application procedures for multiple coats. If work stoppage is unavoidable see sections 5.8 and 5.9.

---

**NOTES:**

CIM will adhere to most clean construction materials. When coating substrates other than wood, please see the C.I.M. Industries' specific substrate Instruction Guide for detailed information and application procedures.

**5.2 Sharp Edges**

CIM 1000 Trowel Grade may be used on sharp edges to prevent thin spots from occurring. The entire area should be coated with the specified thickness of CIM within four (4) hours after troweling sharp edges. Please see section 5.7 for application procedures for multiple coats. If work stoppage is unavoidable see sections 5.8 and 5.9.

**5.3 Using CIM Scrim**

CIM Scrim may also be used on sharp edges to prevent thin spots from occurring. After substrate is properly prepared, apply a thin tack coat, 10–20 mils, of CIM . Push scrim evenly into tack coat and allow to cure for 1–4 hours. Apply a 60 wet mil coating of CIM directly over scrim. CIM Scrim acts as a coverage gauge to insure thickness.

**5.4 Cant Strips**

Cant strips should be made with CIM 1000 Trowel Grade Cartridges wherever horizontal surfaces meet vertical surfaces. This is crucial in applications such as tanks which experience wall movement when filled, and where wood shifts due to expansion and contraction. Cant strips are generally  $\frac{1}{2}$ " or more wide by  $\frac{1}{2}$ " or more tall. Allow the cant to cure for a minimum of 12 hours at 70°F. Contact C.I.M. Industries for specific design details.

**5.5 Horizontal Surfaces**

CIM should be applied to wood at a film thickness of 60 wet mils, depending on application type. This can be achieved in a single coat on horizontal surfaces.

**5.6 Vertical and Sloped Surfaces**

CIM can be applied to a vertical or sloped surface with a roller, brush or spray equipment. Small walls are often coated with rollers or brushes. Large walls should be sprayed using an air assisted airless spray system or plural component spray system. See C.I.M. Industries' Instruction Guide, "Spray Application of CIM" (IG-12) or contact C.I.M. Industries for suggested equipment configuration. When working with CIM, vertical or sloped surfaces require a minimum of two (2) applications of

---

**NOTES:**

approximately 30 mils each to obtain the required thickness. If a coating thickness of more than approximately 60–65 mils is specified on a vertical or sloped surface, additional coats will be required to achieve desired thickness.

### **5.7 Multiple Coats**

Second/multiple coats can be applied as soon as the previous coat can be touched lightly without coming off on your finger. For CIM at 70°F, the tack free time is typically one (1) hour but no longer than four (4) hours after the previous coat has been applied. Higher temperatures speed up the curing time, and tack free time, therefore significantly shortening the 1–4 hour recoat window. Colder temperatures have the opposite effect. As soon as the coating becomes tack free, the second coat should be applied. For immersion or traffic service, apply all coats within the recoat window except at joint lines.

If it is necessary to walk on the first coat of CIM in order to apply multiple coats, such as when coating a parking or pedestrian deck, polyethylene boots may be worn to prevent sticking to the coating.

### **5.8 Recoating After the Recoat Window**

If second/multiple coats cannot be applied within the recoat window (1–4 hours under standard conditions), the previous coat must be abraded. Abrading shall be performed by surface grinder or other mechanical means. The CIM must be solvent wiped (MEK or xylene) to clean up any loose debris. After the solvent flashes off, a light mist of CIM Bonding Agent must be applied. Allow the CIM Bonding Agent to flash off and recoat within one (1) hour. For immersion or traffic service, minimize areas to be recoated outside the recoat window. Severely abrade the areas to be recoated and test recoated areas for acceptable adhesion. Acceptable adhesion may only be achieved through aggressive abrading.

### **5.9 Overlap at Joints**

Should rain or other conditions require work stoppage, prepare for joint lines. Joint lines shall be clean and straight. The overlap shall be a minimum of 6” to insure an impervious joint. All areas to be coated where more than a four (4) hour cure has taken place shall be treated per section 5.8, “Recoating After the Recoat Window.”

---

**NOTES:**

## **6.0 TOPPINGS**

The CIM may include toppings of aggregate, decorative coatings, protective coatings, or combinations of the above. See C.I.M. Industries' Instruction Guide, "Topcoats" (IG-7) for more detailed information.

## **7.0 GENERAL LIMITATIONS**

Applying CIM under any of the following conditions is likely to result in poor or unsatisfactory performance:

- Use of improper mixing equipment. See C.I.M. Industries' Instruction Guide "Mixing CIM Premix and Activator" (IG-8).
- Material temperature at the time of application is below 60°F.
- Use of standard application procedures when substrate temperature is below 50°F. See C.I.M. Industries' Instruction Guide "Applying CIM Coatings in Cold Weather" (IG-11).
- Substrate moisture is present or rain is imminent.
- Substrate temperature is less than 5°F above the dew point.
- Substrate is in a temperature-rising mode or exposed to direct sunlight.
- Other conditions which are obviously unsuitable.